

**Part No.: TBG-180400-3k-90**

## 90 Degree 3dB Bridge

### 电气特性 Electrical:

工作频率 Frequency Range: 18-40GHz  
 耦合度 Coupling : 3dB  
 插入损耗 Insertion Loss: 1.9db typ, 2.0db max  
 隔离度 Isolation: 15db typ, 12db min  
 驻波 VSWR: 1.5 typ, 1.8 max  
 幅度平衡 Amplitude Balance:  $\pm 0.8\text{dB}$  max  
 相位平衡 Phase Balance:  $\leq \pm 10$  degree  
 耐功率 Power Handling: 50 Watt  
 阻抗 Impedance: 50 OHMS

### 机械特性 Mechanical:

温度范围 Temperature Range:  $-45^{\circ}\text{C} - +85^{\circ}\text{C}$   
 接口 Connectors: 2.92-Female  
 相对湿度 Relative Humidity: 0 ~ 90%

### 外形尺寸 Outline Drawing:

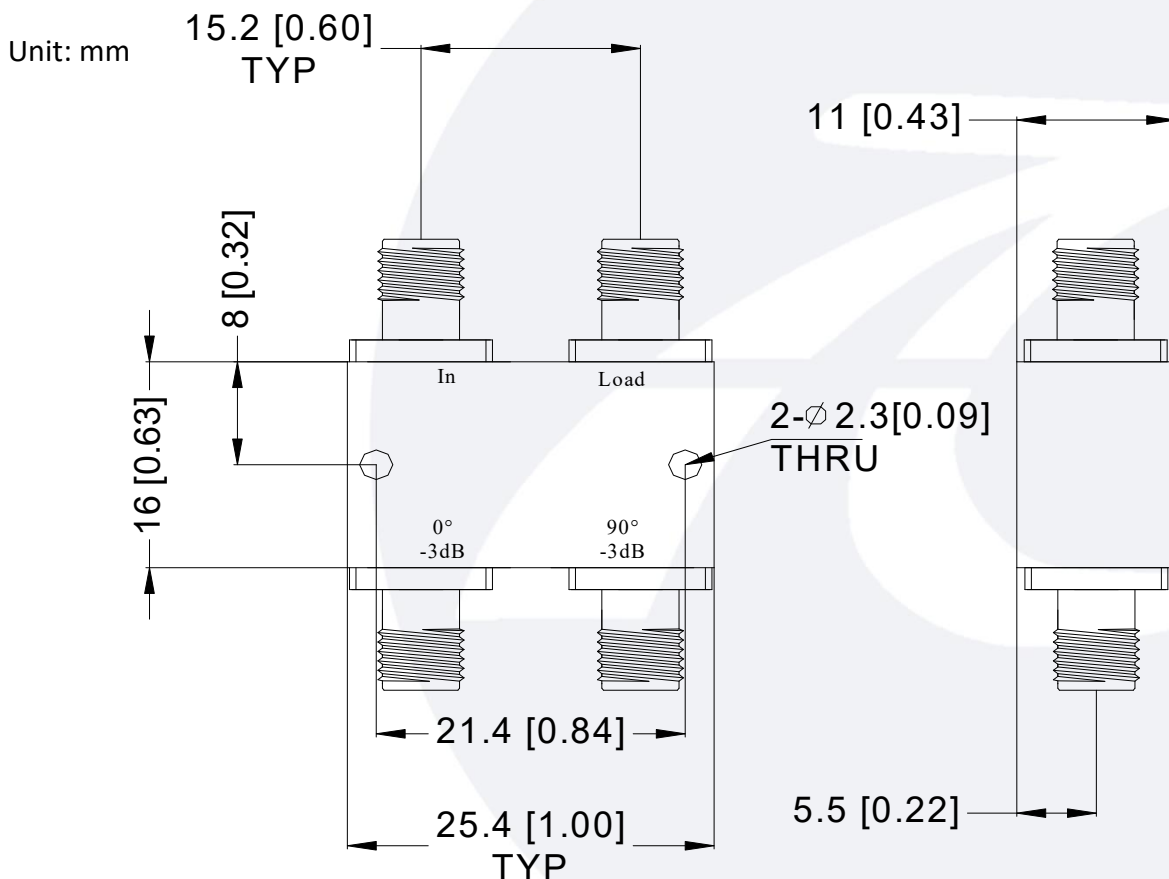

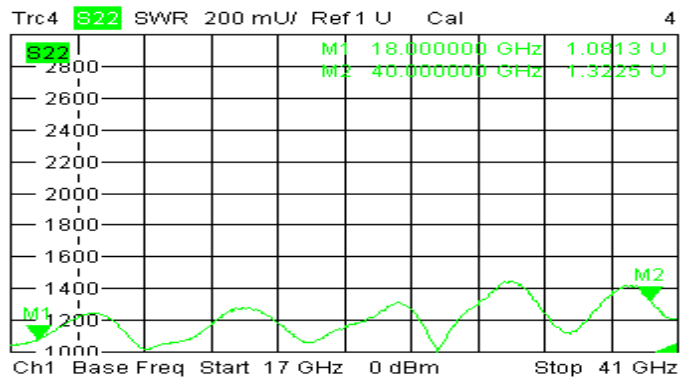
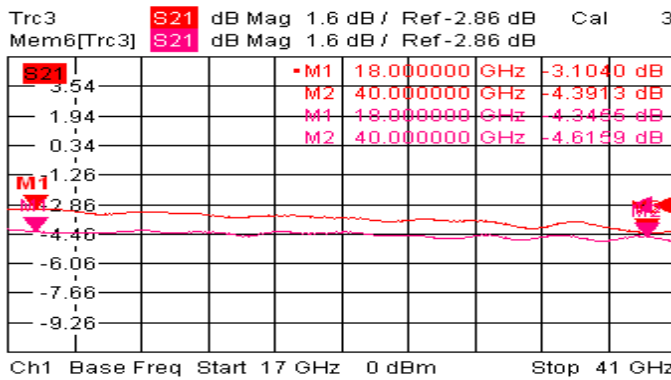
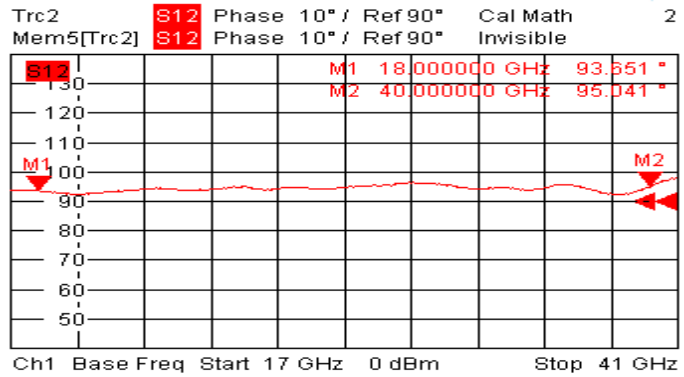
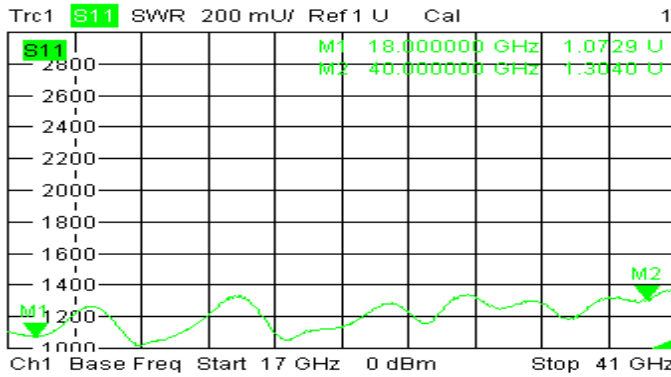

10/20/2018, 5:31 AM

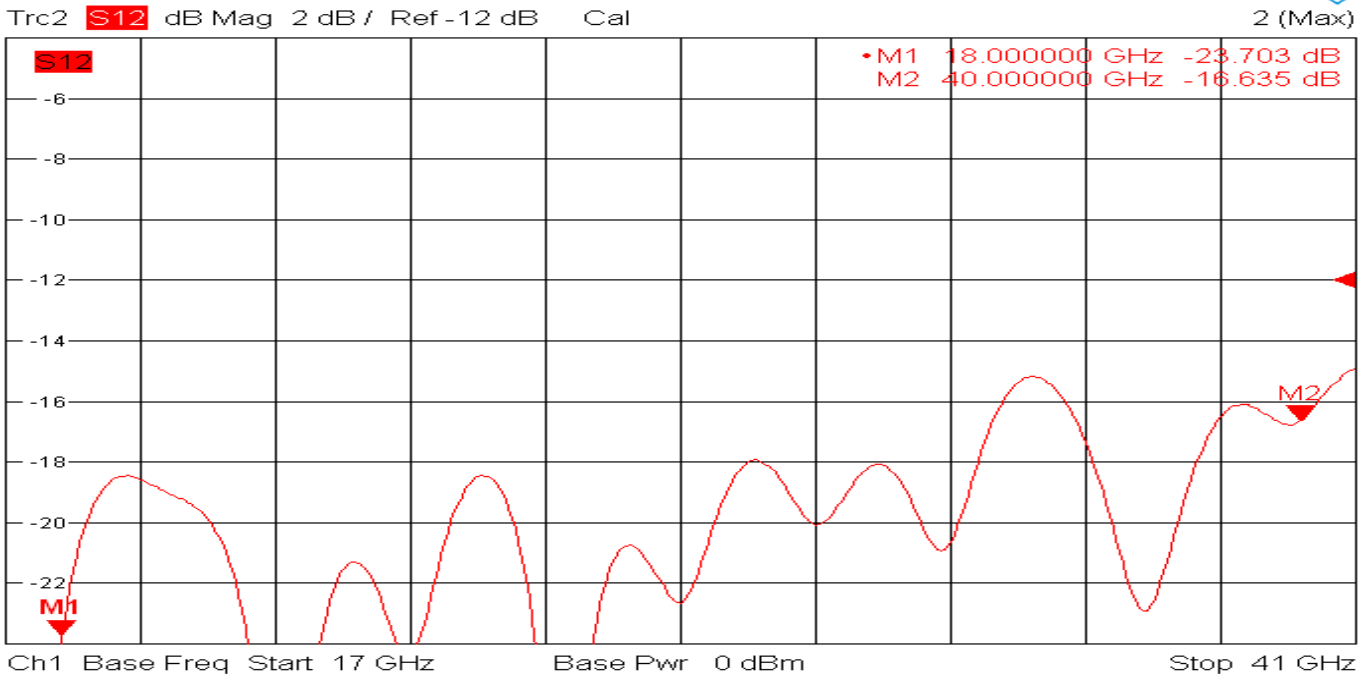

10/20/2018, 5:44 AM