

SP7T to SP8T Electromechanical Switch

Normally Open , DC to 26.5 GHz, 2.92mm, D-SUB

电气参数 Electrical Characteristics:

参数 Parameter	指标 Value
频率范围 Frequency Range	DC-26.5 GHz
阻抗 RF Impedance	50 Ohms
开关模式 Operation Mode	Normally Open
开关顺序 Switch Sequence	Break before make
切换时间 Switching time	15 ms Max
开关寿命 Standard Actuator Life	2 million Min
驱动电压 Actuator Voltage Available	12 24 28 V
驱动电流 Actuator current	290 150 130 mA



射频特性 RF Specifications:

频率范围 Frequency (GHz)	DC-4	4-8	8-12.4	12.4-18	18-26.5
插损 Insertion Loss (dB max.)	0.2	0.3	0.4	0.6	0.8
隔离 Isolation (dB min.)	75	65	60	60	55
驻波 VSWR (max.)	1.2:1	1.3:1	1.4:1	1.6:1	1.8:1
平均功率 RF Power CW (Watts max.)	100	70	60	45	10

环境和物理特性 Environmental And Physical Characteristics:

参数 Parameter	指标 Value
操作温度 Operating Temperature	-25°C to +65°C (Standard) -55°C - +85°C (Optional)
震动 Vibration (operating)	10G RMS, 20-2000HZ
冲击 Shock (non operating)	50G, 1/2 Sine, 12msec
射频接口 Connector Type	2.92mm Female
控制接口 Control Connector	D-SUB 15 PIN Male
重量 Weight	220g Max

外形尺寸 Outline Drawing:

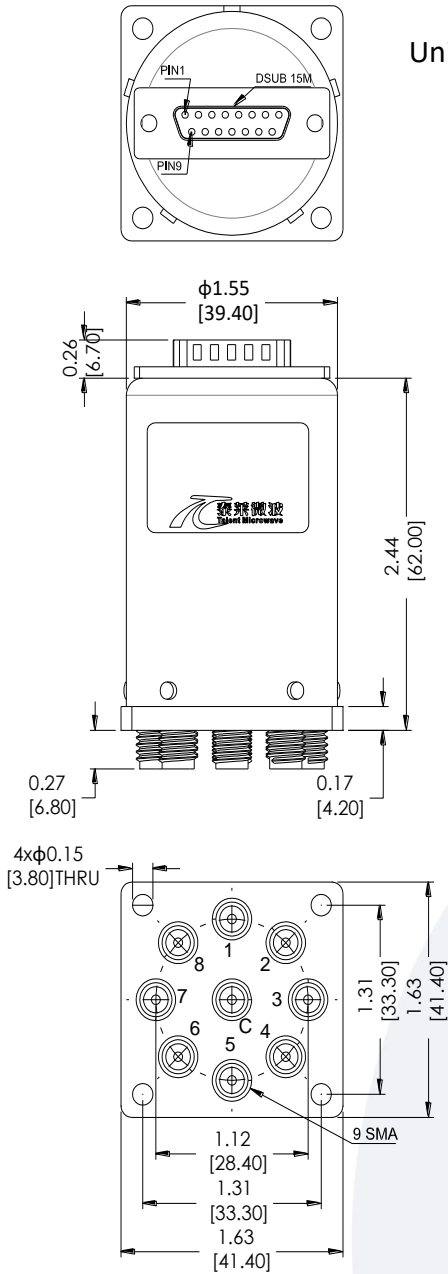

原理图 Schematic:

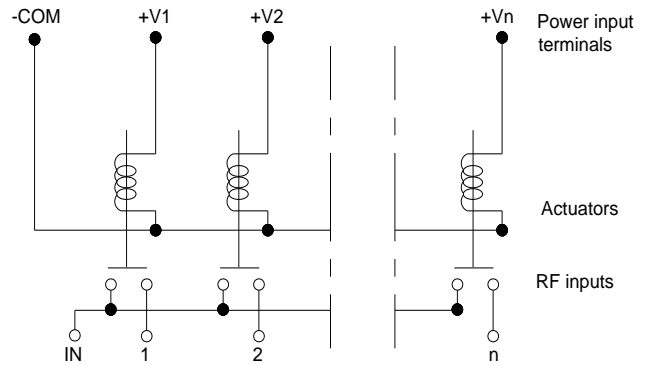

Pin NO	15 PIN D-SUB	RF Connect Used	
	FUNCTION	SP7T	SP8T
1	V1	1	1
2	V2	2	2
3	V3	3	3
4	V4	4	4
5	V5	5	5
6	V6	6	6
7	V7	7	7
8	V8		8
9	-COM		
10	NC		
11	NC		
12	NC		
13	NC		
14	NC		
15	NC		

标准型号 Part Number:

标准型号 Part Number		驱动电压 Actuator voltage	可选项 Option
SP7T	SP8T		
R17-KN12026-D	R18-KN12026-D	12 V	-S(-55°C - +85°C)
R17-KN24026-D	R18-KN24026-D	24 V	
R17-KN28026-D	R18-KN28026-D	28 V	