

## Flexible Ultra Low Loss Coax Cable Assembly

A50/SMA Male / SMA Female/DC-18 GHz

Model: A50-SMAMSMAF-L

### Features:

- Max Frequency 18 GHz
- VSWR max of 1.30
- Velocity of Propagation of 83%

### Applications:

- Test & Measurement equipment
- Manufacturing lab
- WAN system equipment

### Cable Cross Section:

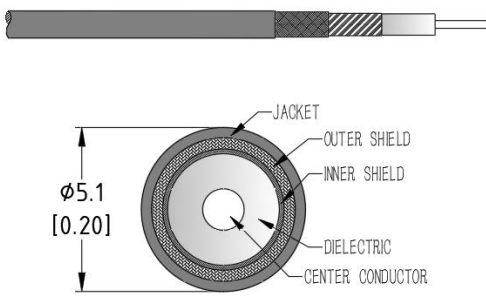

### Electrical Characteristics:

Parameter	Min	Typ	Max	Units
Frequency Range	DC		18	GHz
VSWR		1.25	1.3	:1
Velocity of propagation		83%		
Shielding Effectiveness	90			dB
Capacitance			80	pF/m
Phase Stability Vs. Flexure@18GHz		±2		°
Amplitude Stability Vs. Flexure@18GHz		±0.03		dB
Phase Stability Vs. Temperature			550	PPM

### Environmental And Physical Characteristics:

Description	Parameter	Units
Cable Diameter	5.1	mm
Cable Jacket	FEP	
Min. Bending Radius	26	mm
Typical Flex life	50000	
Operating Temperature	-55 to +125	°C
Storage Temperature	-55 to +165	°C

### Cable Performance By Frequency:

Frequency	2 GHz	4 GHz	6 GHz	8 GHz	10 GHz	12 GHz	16 GHz	18 GHz
Insertion Loss (dB/m Max)	0.33	0.47	0.57	0.67	0.75	0.82	0.96	1.02
RF Power CW (W Max.)	615	431	350	302	268	244	210	197

### Connectors:

Description	Connector 1	Connector 2
Type	SMA Straight Male	SMA Straight Female
Contact Material And Plating	Brass,Gold	Beryllium Copper,Gold
Dielectric Type	PTFE	PTFE
Body Material And Plating	Passivated Stainless Steel	Passivated Stainless Steel
Insertion Loss (dB Max)	$0.05 * \sqrt{f\_GHz}$	$0.05 * \sqrt{f\_GHz}$

### Outline Drawing:

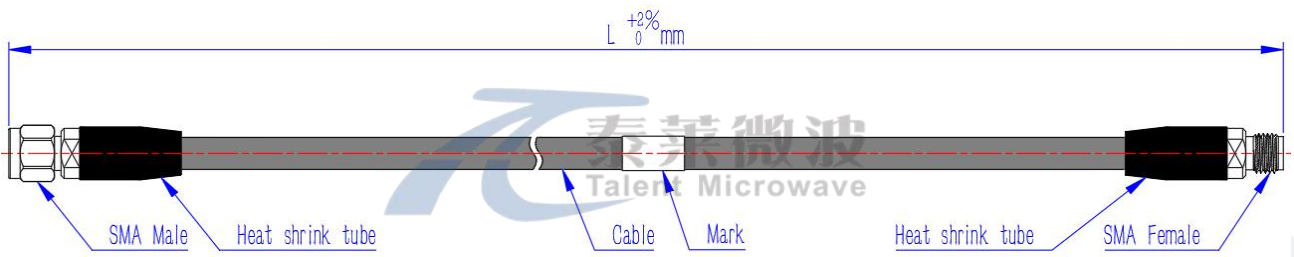

### Ordering Information:

Base Number	Length (Unit meters)	Armour	Phase/delay Matched
A50-SMAMSMFAF	-L	<b>LEAVE BLANK(NOT REQUIRED)</b> -A(默认黑色尼龙铠甲) -AS(不锈钢铠甲) -AP(PUR防水铠甲) -AT(透明铠甲)	<b>LEAVE BLANK(NOT REQUIRED)</b> -XXPS( $\pm XX$ PS) -XX°( $\pm XX^\circ$ )

### Typical Performance Data:

Model:A50-SMAMSMFAF-1m

Frequency	2 GHz		6 GHz		8 GHz		12 GHz		18 GHz	
	Typ	Max	Typ	Max	Typ	Max	Typ	Max	Typ	Max
Insertion Loss	0.40	0.47	0.70	0.82	0.81	0.95	1.00	1.17	1.23	1.44
VSWR	1.05	1.1	1.08	1.15	1.15	1.2	1.2	1.25	1.25	1.3