

Flexible Cable Replacing Remi-rigid Cable Assembly

T2/SMA Male / SMA Male/DC-26.5 GHz

Model: T2-SMAMSMAM-L

Features:

- Max Frequency 26.5 GHz
- VSWR max of 1.30
- Velocity of Propagation of 70%

Applications:

- Test & Measurement equipment
- Manufacturing lab
- WAN system equipment

Cable Cross Section:

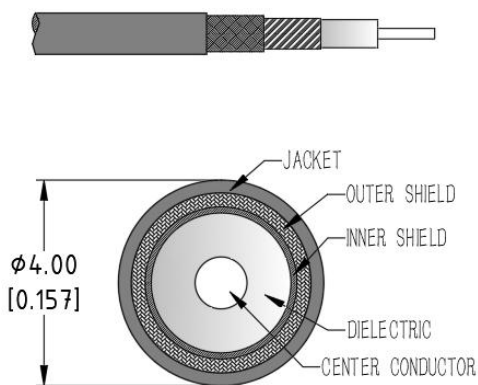

Electrical Characteristics:

Parameter	Min	Typ	Max	Units
Frequency Range	DC		26.5	GHz
VSWR		1.25	1.3	:1
Velocity of propagation		70%		
Shielding Effectiveness	90			dB
Capacitance			81	pF/m
Phase Stability Vs. Flexure@18GHz		± 8		$^{\circ}$
Amplitude Stability Vs. Flexure@18GHz		± 0.1		dB

Environmental And Physical Characteristics:

Description	Parameter	Units
Cable Diameter	4.0	mm
Cable Jacket	FEP	
Min. Bending Radius	20	mm
Typical Flex life	50000	
Operating Temperature	-55 to +125	$^{\circ}\text{C}$
Storage Temperature	-55 to +125	$^{\circ}\text{C}$

Cable Performance By Frequency

Frequency	2 GHz	4 GHz	6 GHz	8 GHz	12 GHz	16 GHz	18 GHz	26.5 GHz
Insertion Loss (dB/m Max)	0.56	0.84	1.07	1.29	1.66	2.00	2.16	2.81
RF Power CW (W Max.)	181	121	95	79	62	51	47	36

Connectors:

Description	Connector 1	Connector 2
Type	SMA Straight Male	SMA Straight Male
Contact Material And Plating	Brass,Gold	Brass,Gold
Dielectric Type	PTFE	PTFE
Body Material And Plating	Passivated Stainless Steel	Passivated Stainless Steel
Insertion Loss (dB Max)	$0.05 * \sqrt{f_GHz}$	$0.05 * \sqrt{f_GHz}$

Outline Drawing:

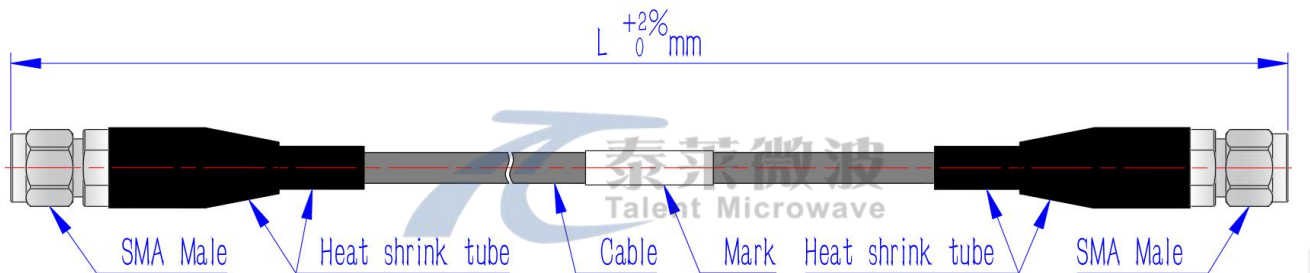

Ordering Information:

Base Number	Length (Unit meters)	Phase/delay Matched
T2-SMAMSMAM	-L	LEAVE BLANK (NOT REQUIRED) -XXPS ($\leq \pm XX$ PS) -XX° ($\pm XX^\circ$)

Typical Performance Data:

Model: T2-SMAMSMAM-1m

Frequency	2 GHz		6 GHz		12 GHz		18 GHz		26.5 GHz	
	Typ	Max	Typ	Max	Typ	Max	Typ	Max	Typ	Max
Insertion Loss	0.63	0.70	1.20	1.32	1.83	2.00	2.37	2.59	3.06	3.32
VSWR	1.05	1.10	1.10	1.15	1.15	1.20	1.20	1.25	1.25	1.30