

Flexible Ultra Low Loss Coax Cable Assembly

M5/1.0mm Male /1.0mm Male/DC-110 GHz

Model: M5-1.0M1.0M-L

Features:

- Max Frequency 110 GHz
- VSWR max of 1.50
- Velocity of Propagation of 80%

Applications:

- Test & Measurement equipment
- Manufacturing lab
- WAN system equipment

Cable Cross Section:

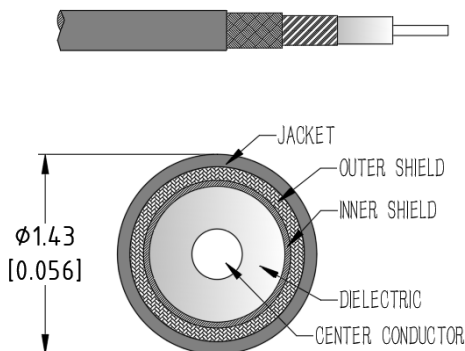

Electrical Characteristics:

Parameter	Min	Typ	Max	Units
Frequency Range	DC		110	GHz
VSWR		1.45	1.50	:1
Velocity of propagation		80%		
Shielding Effectiveness	90			dB
Capacitance			81	pF/m
Phase Stability Vs. Flexure		±8		°
Amplitude Stability Vs. Flexure		±0.08		dB
Phase Stability Vs. Temperature			550	PPM

Environmental And Physical Characteristics:

Description	Parameter	Units
Cable Diameter	1.43	mm
Cable Jacket	FEP	
Min. Bending Radius	6	mm
Typical Flex life	50000	
Operating Temperature	-55 to +125	°C
Storage Temperature	-55 to +165	°C

Cable Performance By Frequency

Frequency	2 GHz	4 GHz	6 GHz	8 GHz	12 GHz	18 GHz	26.5 GHz	40GHz	50 GHz	67GHz	110GHz
Insertion Loss (dB/m Max.)	1.62	2.30	2.83	3.28	4.04	4.99	6.12	7.60	8.57	10.03	13.14
RF Power CW (W Max.)	27	19	16	14	11	9	7	6	5	4	3

Connectors:

Description	Connector 1	Connector 2
Type	1.0mm Straight Male	1.0mm Straight Male
Contact Material And Plating	Beryllium Copper, Gold	Beryllium Copper, Gold
Dielectric Type	PTFE	PTFE
Body Material And Plating	Passivated Stainless Steel	Passivated Stainless Steel
Insertion Loss (dB Max)	0.05* $\sqrt{f_GHz}$	0.05* $\sqrt{f_GHz}$

Outline Drawing:

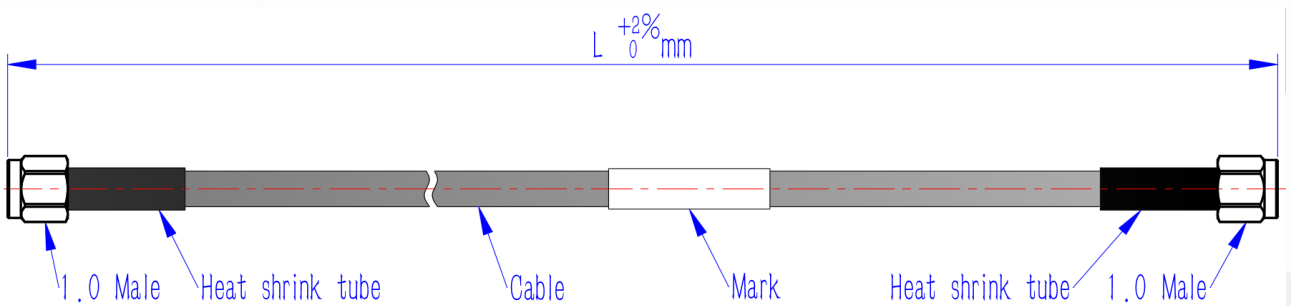

Ordering Information:

Base Number	Length (Unit meters)	Armour	Phase/delay Matched
M5-1.0M1.0M	-L	LEAVE BLANK (NOT REQUIRED) -A(默认黑色尼龙铠甲) -AS(不锈钢铠甲) -AP(PUR防水铠甲) -AT(透明铠甲)	LEAVE BLANK (NOT REQUIRED) -XXPS($\pm XX$ PS) -XX°($\pm XX^\circ$)

Typical Performance Data:

Model: M5-1.0M1.0M-1m

Frequency	2 GHz		18 GHz		26.5 GHz		40GHz		50GHz		67GHz		110GHz	
	Typ	Max	Typ	Max	Typ	Max	Typ	Max	Typ	Max	Typ	Max	Typ	Max
Insertion Loss	1.69	1.76	5.21	5.42	6.37	6.63	7.92	8.24	8.92	9.27	10.44	10.85	13.67	14.19
VSWR	1.05	1.10	1.15	1.20	1.20	1.25	1.25	1.30	1.30	1.35	1.40	1.45	1.45	1.50