

UF Series Ultra-Flexible Assembly

UF2/SMA
Male/SMA Male/DC-18 GHz
Model: UF2-SMAMSMAM-L

Features:

- Max Frequency 26.5 GHz
- VSWR max of 1.30
- Velocity of Propagation of 76%

Applications:

- Test & Measurement equipment
- Manufacturing lab
- WAN system equipment

Cable Cross Section:

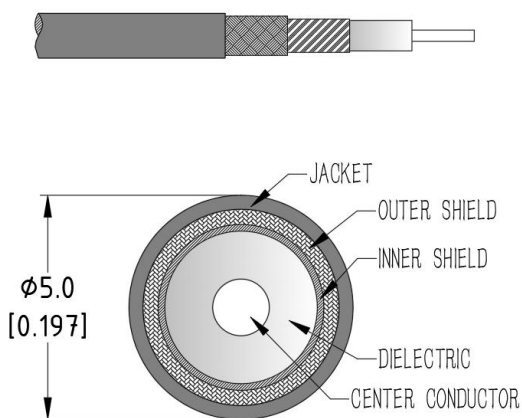

Electrical Characteristics:

Parameter	Min	Typ	Max	Units
Frequency Range	DC		26.5	GHz
VSWR		1.25	1.3	:1
Velocity of propagation		76%		
Shielding Effectiveness	90			dB
Capacitance			81	pF/m
Phase Stability Vs. Flexure@18GHz		± 3		$^{\circ}$
Amplitude Stability Vs. Flexure@18GHz		± 0.05		dB
Phase Stability Vs. Temperature		1000		PPM

Environmental And Physical Characteristics:

Description	Parameter	Units
Cable Diameter	5.0	mm
Cable Jacket	PUR	
Min. Bending Radius	20	mm
Typical Flex life	50000	
Operating Temperature	-55 to +85	$^{\circ}\text{C}$
Storage Temperature	-55 to +85	$^{\circ}\text{C}$

Cable Performance By Frequency

Frequency	2 GHz	4 GHz	6 GHz	8 GHz	10 GHz	12 GHz	16 GHz	18 GHz	26.5 GHz
Insertion Loss (dB/m Max.)	0.56	0.82	1.03	1.22	1.39	1.55	1.84	1.98	2.52
RF Power CW (W Max.)	115	78	62	53	46	41	35	32	25

Connectors:

Description	Connector 1	Connector 2
Type	SMA Straight Male	SMA Straight Male
Contact Material And Plating	Brass,Gold	Brass,Gold
Dielectric Type	PTFE	PTFE
Body Material And Plating	Passivated Stainless Steel	Passivated Stainless Steel
Insertion Loss (dB Max)	$0.05 * \sqrt{f_GHz}$	$0.05 * \sqrt{f_GHz}$

Outline Drawing:

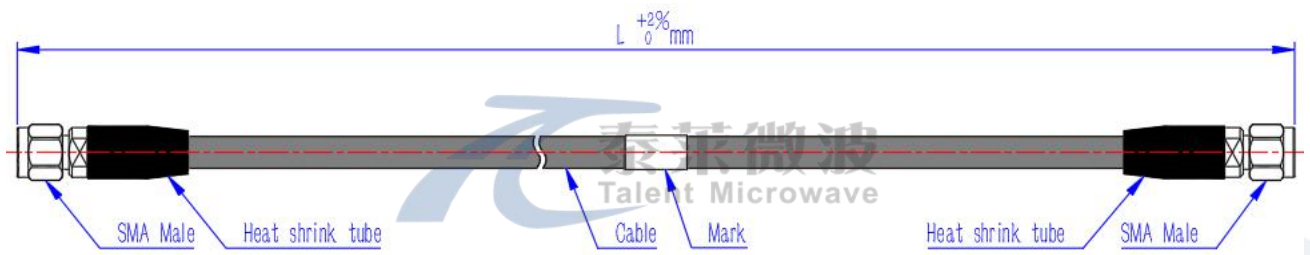

Ordering Information:

Base Number	Lenth (Unit meters)	Phase/delay Matched
UF2-SMAMSMAM	-L	LEAVE BLANK(NOT REQUIRED) -XXPS($\leq \pm XX$ PS) -XX°($\pm XX^\circ$)

Typical Performance Data:

Model:UF2-SMAMSMAM-1m

Frequency	2 GHz		6 GHz		12 GHz		18 GHz	
	Typ	Max	Typ	Max	Typ	Max	Typ	Max
Insertion Loss	0.63	0.70	1.15	1.28	1.72	1.90	2.19	2.40
VSWR	1.05	1.10	1.15	1.20	1.20	1.30	1.25	1.30

