

## SPDT Electromechanical Switch

**Pulse Latching, DC to 18 GHz, TTL, SMA, Terminated, Solder Pin**

### 电气参数 Electrical Characteristics:

参数Parameter	条件Condition
频率范围 Frequency Range	DC-18 GHz
阻抗 RF Impedance	50 Ohms
开关模式 Operation Mode	Pulse Latching
开关顺序 Switch Sequence	Break before make
切换时间 Switching time	15 ms Max
开关寿命 Standard Actuator Life	5 million Min
TTL 电压 TTL Voltage	0-0.8 V(OFF) 2.4-5 V(ON)
驱动电压 Actuator voltage Available	12 24 28 V
驱动电流 Actuator current	200 100 80 mA
负载功率 Termination Power CW	2 W



### 射频特性 RF Specifications:

频率范围 Frequency (GHz)	DC-6	6-12	12-18
插损 Insertion Loss (dB max.)	0.2	0.25	0.4
隔离 Isolation (dB min.)	70	70	60
驻波 VSWR (max.)	1.2:1	1.3:1	1.4:1
平均功率 RF Power CW (Watts max.)	80	60	50

### 环境和物理特性 Environmental And Physical Characteristics:

参数Parameter	条件 Condition
操作温度 Operating Temperature	-25°C to +65°C(Standard ) -55°C to +85°C(Optional)
震动 Vibration(operating)	10G RMS, 20-2000HZ
冲击 Shock(non operating)	50G, 1/2Sine, 12msec
射频接口 Connector Type	SMA Female
控制接口 Control Connector	Solder Pin
重量 Weight	100g Max

### 外形尺寸 Outline Drawing:

Unit: Inch(mm)

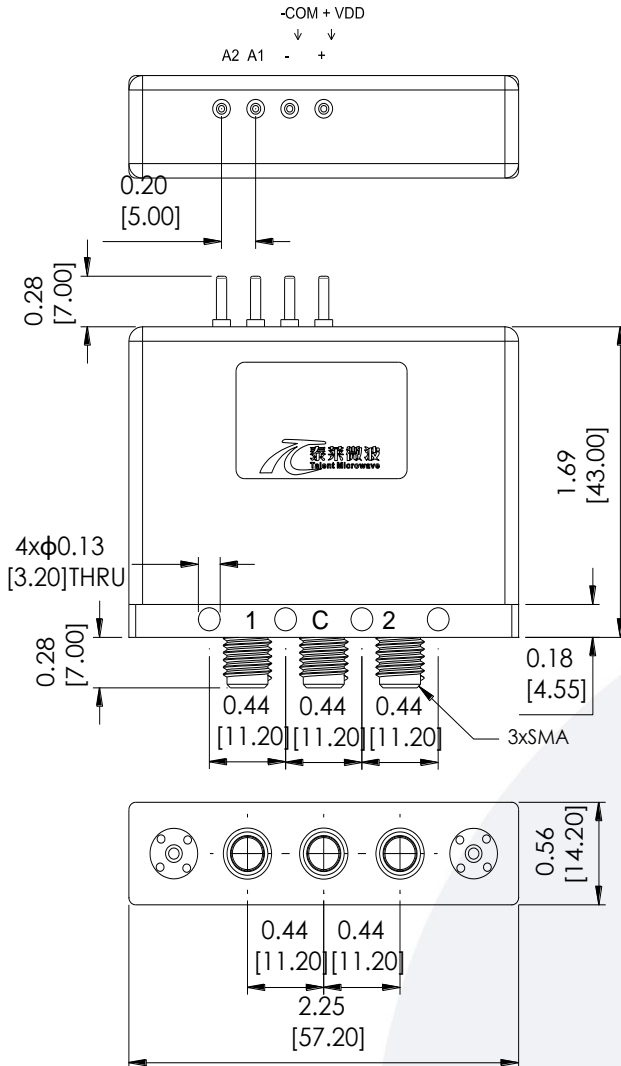

### 原理图 Schematic:

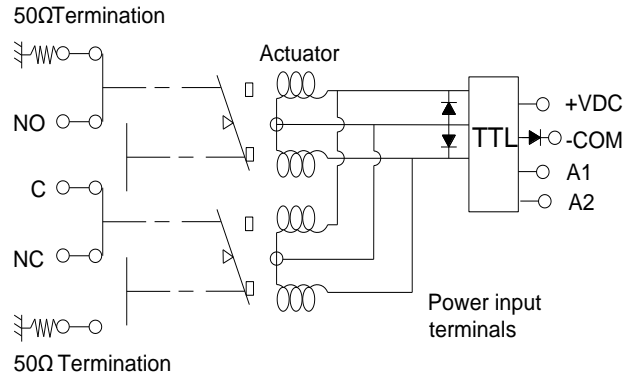

### 标准型号 Outline Drawing:

标准型号 Model	驱动电压 Actuator voltage	可选项 Option
R12-SL12T18-T	12 V	-S(-55°C - +85°C)
R12-SL24T18-T	24 V	
R12-SL28T18-T	28 V	

**典型曲线 Typical Performance Data:**

INSERTION LOSS

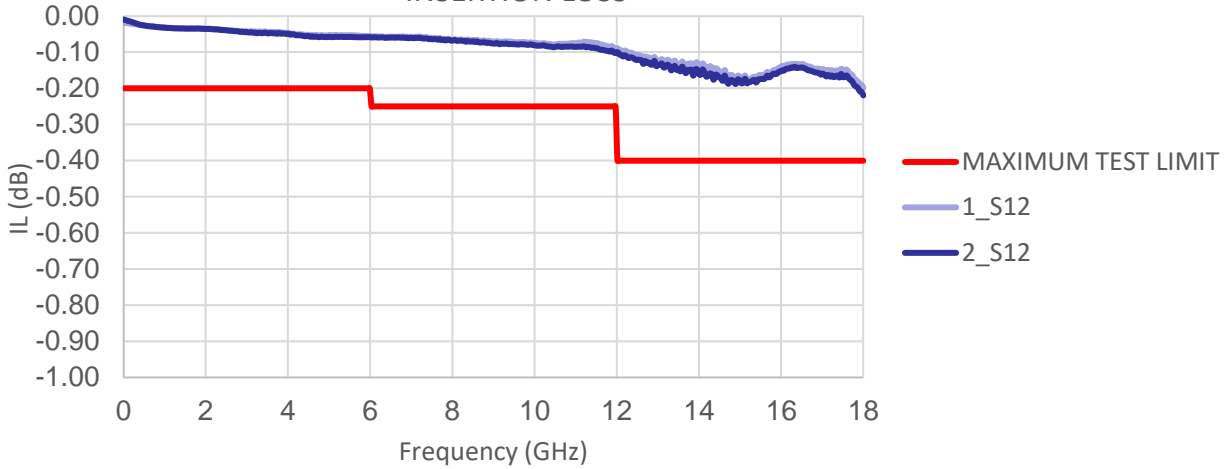

VSWR

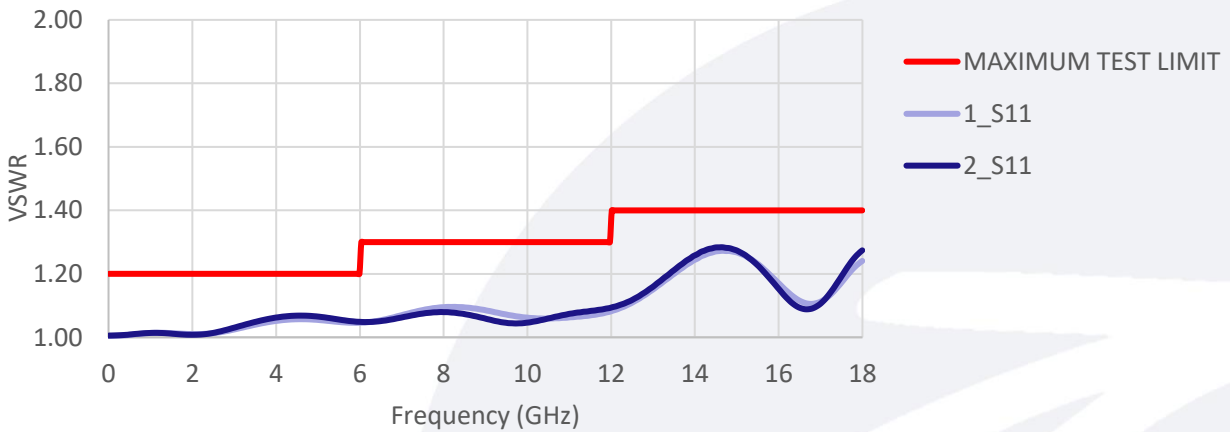

ISOLATION

