

TLBend Ultra Flexible RF Cable Assembly

TLBend086/SMA Male /SMA Male/DC-26.5GHz

Model: TLBend086-SMAMSMAM-L



Features:

- Max Frequency 26.5GHz
- VSWR max of 1.35
- Velocity of Propagation of 70%

Applications:

- Test & Measurement equipment
- Manufacturing lab
- WAN system equipment

Cable Cross Section:

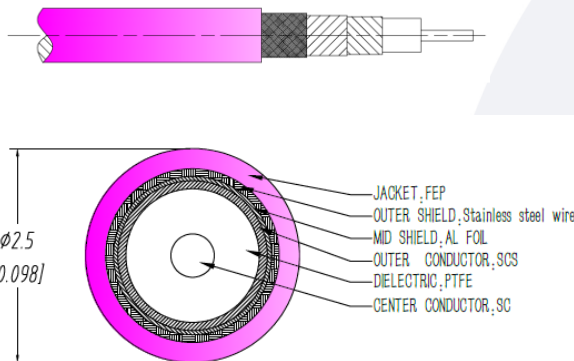

Electrical Characteristics:

Parameter	Min	Typ	Max	Units
Frequency Range	DC		26.5	GHz
VSWR		1.25	1.35	:1
Velocity of propagation		70%		
Shielding Effectiveness	90			dB
Capacitance		95.2		pF/m
Phase Stability Vs. Flexure@26.5GHz		± 3		$^{\circ}$
Amplitude Stability Vs. Flexure@26.5GHz		± 0.08		dB

Environmental And Physical Characteristics:

Description	Parameter	Units
Cable Diameter	2.5	mm
Cable Jacket	FEP	
Min. Static Bending Radius	5.08	mm
Min. Repeated Bending Radius	25	mm
Operating Temperature	-55 to +125	$^{\circ}\text{C}$
Storage Temperature	-55 to +125	$^{\circ}\text{C}$

Cable Performance By Frequency:

Frequency	1 GHz	1.5 GHz	2 GHz	4 GHz	6 GHz	8 GHz	10 GHz	12 GHz	18 GHz	26.5 GHz
Insertion Loss (dB/m Max.)	0.83	1.02	1.18	1.68	2.07	2.41	2.71	2.98	3.69	4.54
RF Power CW (W Max.)	103	84	73	51	41	36	32	28	23	19

Connectors:

Description	Connector 1	Connector 2
Type	SMA Male	SMA Male
Contact Material And Plating	Beryllium Copper, Gold	Beryllium Copper, Gold
Dielectric Type	PEI	PEI
Body Material And Plating	Passivated Stainless Steel	Passivated Stainless Steel
Insertion Loss (dB Max)	$0.05 * \text{Sqrt}(f_GHz)$	$0.05 * \text{Sqrt}(f_GHz)$

Outline Drawing:

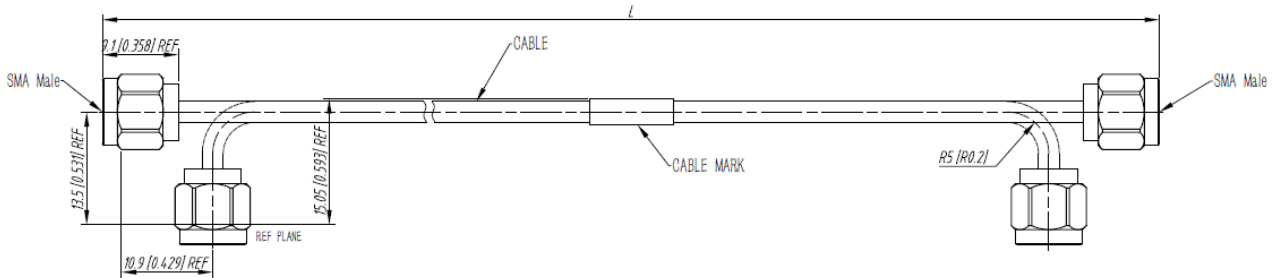

Ordering Information:

Base Number	Length (Inches)
TLBend086-SMAMSMAM	-L

Standard Model:

Part#	L (Inch)	2 GHz		12.4 GHz		18 GHz		24 GHz	
		VSWR	IL(dB)	VSWR	IL(dB)	VSWR	IL(dB)	VSWR	IL(dB)
TLBend086-SMAMSMAM-3	3	1.15	0.19	1.20	0.40	1.30	0.54	1.30	0.63
TLBend086-SMAMSMAM-4	4	1.15	0.23	1.20	0.48	1.30	0.65	1.30	0.75
TLBend086-SMAMSMAM-6	6	1.15	0.29	1.20	0.65	1.30	0.84	1.30	0.99
TLBend086-SMAMSMAM-8	8	1.15	0.35	1.20	0.82	1.30	1.05	1.30	1.22
TLBend086-SMAMSMAM-10	10	1.15	0.41	1.20	0.98	1.30	1.24	1.30	1.46
TLBend086-SMAMSMAM-12	12	1.15	0.47	1.20	1.15	1.30	1.42	1.30	1.68
TLBend086-SMAMSMAM-14	14	1.15	0.56	1.20	1.35	1.30	1.62	1.30	1.92
TLBend086-SMAMSMAM-16	16	1.15	0.60	1.20	1.46	1.30	1.81	1.30	2.14
TLBend086-SMAMSMAM-18	18	1.15	0.66	1.20	1.64	1.30	2.05	1.30	2.38
TLBend086-SMAMSMAM-20	20	1.15	0.71	1.20	1.80	1.30	2.25	1.30	2.60

Typical Performance Data:

Model: :TLBend086-SMAMSMAM-4

