

TLBend Ultra Flexible RF Cable Assembly

TLBend086H/2.92 Male /2.92 Male/DC-40GHz

Model: TLBend086H-2.92M2.92M-L



Features:

- Max Frequency 40GHz
- VSWR max of 1.35
- Velocity of Propagation of 76%

Applications:

- Test & Measurement equipment
- Manufacturing lab
- WAN system equipment

Cable Cross Section:

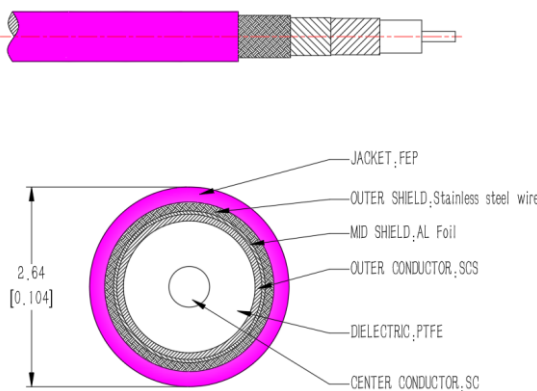

Electrical Characteristics:

Parameter	Min	Typ	Max	Units
Frequency Range	DC		40	GHz
VSWR		1.25	1.35	:1
Velocity of propagation		76%		
Shielding Effectiveness	90			dB
Capacitance		95.2		pF/m
Phase Stability Vs. Flexure@26.5GHz		±4		°
Amplitude Stability Vs. Flexure@26.5GHz		±0.08		dB

Environmental And Physical Characteristics:

Description	Parameter	Units
Cable Diameter	2.64	mm
Cable Jacket	FEP	
Min. Static Bending Radius	10.56	mm
Min. Repeated Bending Radius	26.4	mm
Operating Temperature	-55 to +165	°C
Storage Temperature	-55 to +165	°C

Cable Performance By Frequency:

Frequency	1 GHz	2 GHz	4 GHz	6 GHz	8 GHz	10 GHz	12 GHz	18 GHz	26.5 GHz	35 GHz	40 GHz
Insertion Loss (dB/m Max.)	0.60	0.86	1.23	1.52	1.77	1.99	2.19	2.73	3.37	3.93	4.24
RF Power CW (W Max.)	103	72	50	41	35	31	28	23	18	16	15

Connectors:

Description	Connector 1	Connector 2
Type	2.92mm Male	2.92mm Male
Contact Material And Plating	Beryllium Copper, Gold	Beryllium Copper, Gold
Dielectric Type	PEI	PEI
Body Material And Plating	Passivated Stainless Steel	Passivated Stainless Steel
Insertion Loss (dB Max)	$0.05 * \sqrt{f_GHz}$	$0.05 * \sqrt{f_GHz}$

Outline Drawing:

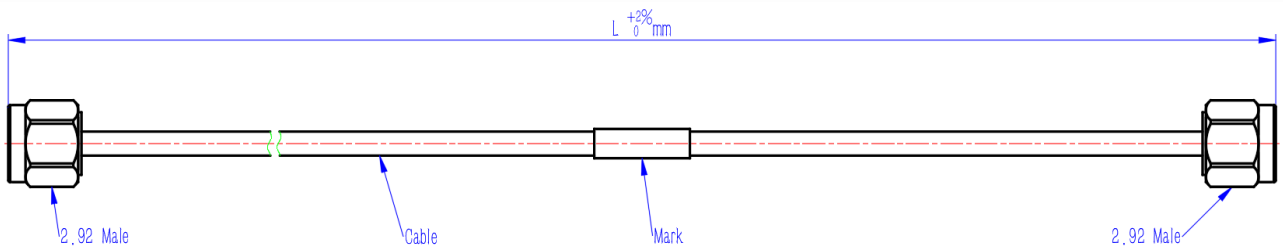

Ordering Information:

Base Number	Length (Inches)
TLBend086H-2.92M2.92M	-L

Standard Model:

Part#	L (inch)	2 GHz		12.4 GHz		18 GHz		26.5 GHz		40GHz	
		VSWR	IL(dB)	VSWR	IL(dB)	VSWR	IL(dB)	VSWR	IL(dB)	VSWR	IL(dB)
TLBend086H-2.92M2.92M-3	3	1.15	0.14	1.20	0.35	1.25	0.42	1.30	0.51	1.35	0.64
TLBend086H-2.92M2.92M-4	4	1.15	0.16	1.20	0.40	1.25	0.49	1.30	0.60	1.35	0.75
TLBend086H-2.92M2.92M-6	6	1.15	0.20	1.20	0.52	1.25	0.63	1.30	0.77	1.35	0.96
TLBend086H-2.92M2.92M-8	8	1.15	0.25	1.20	0.63	1.25	0.77	1.30	0.94	1.35	1.18
TLBend086H-2.92M2.92M-10	10	1.15	0.29	1.20	0.74	1.25	0.91	1.30	1.11	1.35	1.39
TLBend086H-2.92M2.92M-12	12	1.15	0.33	1.20	0.86	1.25	1.04	1.30	1.29	1.35	1.61
TLBend086H-2.92M2.92M-14	14	1.15	0.38	1.20	0.97	1.25	1.18	1.30	1.46	1.35	1.82
TLBend086H-2.92M2.92M-16	16	1.15	0.42	1.20	1.08	1.25	1.32	1.30	1.63	1.35	2.04
TLBend086H-2.92M2.92M-18	18	1.15	0.46	1.20	1.20	1.25	1.46	1.30	1.80	1.35	2.25
TLBend086H-2.92M2.92M-20	20	1.15	0.51	1.20	1.31	1.25	1.60	1.30	1.97	1.35	2.47

Typical Performance Data:

Model: :TLBend086-SMAMSMAM-4

