

TLBend Ultra Flexible RF Cable Assembly

TLBend141/SMA Male /SMA Male/DC-26.5GHz

Model: TLBend141-SMAMSMAM-L



Features:

- Max Frequency 26.5GHz
- VSWR max of 1.35
- Velocity of Propagation of 76%

Applications:

- Test & Measurement equipment
- Manufacturing lab
- WAN system equipment

Cable Cross Section:

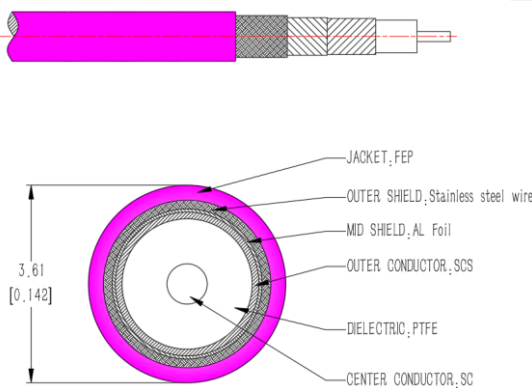

Electrical Characteristics:

Parameter	Min	Typ	Max	Units
Frequency Range	DC		26.5	GHz
VSWR		1.25	1.35	:1
Velocity of propagation		76%		
Shielding Effectiveness	90			dB
Capacitance		95.2		pF/m
Phase Stability Vs. Flexure@26.5GHz		±4		°
Amplitude Stability Vs. Flexure@26.5GHz		±0.08		dB

Environmental And Physical Characteristics:

Description	Parameter	Units
Cable Diameter	3.61	mm
Cable Jacket	FEP	
Min. Static Bending Radius	8.4	mm
Min. Repeated Bending Radius	36	mm
Operating Temperature	-55 to +125	°C
Storage Temperature	-55 to +125	°C

Cable Performance By Frequency:

Frequency	1 GHz	1.5 GHz	2 GHz	4 GHz	6 GHz	8 GHz	10 GHz	12 GHz	18 GHz	26.5 GHz
Insertion Loss (dB/m Max.)	0.40	0.49	0.57	0.81	1.00	1.16	1.30	1.43	1.78	2.19
RF Power CW (W Max.)	346	282	243	170	138	119	106	96	78	63

Connectors:

Description	Connector 1	Connector 2
Type	SMA Male	SMA Male
Contact Material And Plating	Beryllium Copper, Gold	Beryllium Copper, Gold
Dielectric Type	PTFE	PTFE
Body Material And Plating	Passivated Stainless Steel	Passivated Stainless Steel
Insertion Loss (dB Max)	$0.05 * \sqrt{f_GHz}$	$0.05 * \sqrt{f_GHz}$

Outline Drawing:

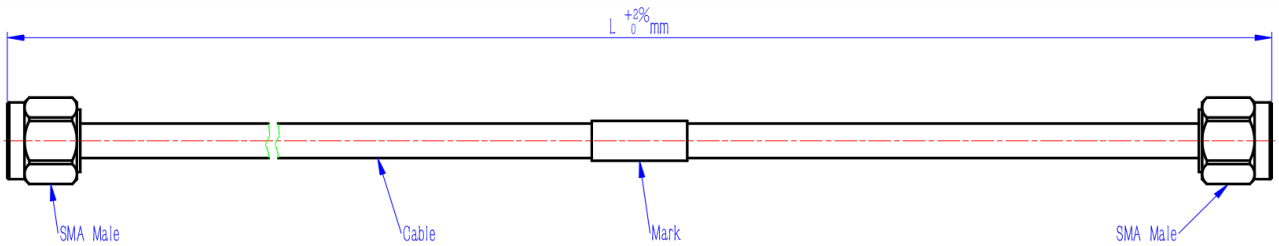

Ordering Information:

Base Number	Length (Inches)
TLBend141-SMAMSMAM	-L

Standard Model:

Part#	L (Inch)	2 GHz		12.4 GHz		18 GHz		26.5 GHz	
		VSWR	IL(dB)	VSWR	IL(dB)	VSWR	IL(dB)	VSWR	IL(dB)
TLBend141-SMAMSMAM-3	3	1.15	0.11	1.20	0.29	1.30	0.35	1.35	0.42
TLBend141-SMAMSMAM-4	4	1.15	0.13	1.20	0.32	1.30	0.39	1.35	0.48
TLBend141-SMAMSMAM-6	6	1.15	0.16	1.20	0.40	1.30	0.48	1.35	0.59
TLBend141-SMAMSMAM-8	8	1.15	0.19	1.20	0.47	1.30	0.57	1.35	0.70
TLBend141-SMAMSMAM-10	10	1.15	0.21	1.20	0.55	1.30	0.66	1.35	0.81
TLBend141-SMAMSMAM-12	12	1.15	0.24	1.20	0.62	1.30	0.75	1.35	0.92
TLBend141-SMAMSMAM-14	14	1.15	0.27	1.20	0.69	1.30	0.84	1.35	1.04
TLBend141-SMAMSMAM-16	16	1.15	0.30	1.20	0.77	1.30	0.93	1.35	1.15
TLBend141-SMAMSMAM-18	18	1.15	0.33	1.20	0.84	1.30	1.03	1.35	1.26
TLBend141-SMAMSMAM-20	20	1.15	0.36	1.20	0.92	1.30	1.12	1.35	1.37