

Model: TLSPDT0.5G40GA
Absorption, Broadband PIN Switch, 0.5-40GHz,
Feature:

- Ultra Broadband: 0.5-40 GHz
- Low Insertion Loss: 3.0 dB
- Power Handling : 23 dBm
- High Isolation
- Switch Type: Absorption

电气特性 Electrocal:

参数Parameter	Min.	Typ.	Max.	Units
频率范围 Frequency range	0.5-40			GHz
插损 Insertion Loss		3.0	5.0	dB
隔离 Isolation	55	75		dB
输入驻波 Input VSWR			2.8	:1
输出驻波 Output VSWR			2.8	:1
切换速度 Switch Speed			60	ns
最大输入功率RF Input Power			23	dBm
TTL逻辑 Control Logic TTL	"1"=J0-J1 ; "0"=J0-J2			
开关类型Switch Type	Absorption			
阻抗 Impedance	50			Ohms

机械特性 Mechanical :

参数Parameter	Specification	Units
输入输出接口 Input /Output Connector	2.92mm Female	
直流偏置 Bias	Solder Pin	
尺寸 Size	27*17*12	mm

外形尺寸 Outline Drawing:

Unit: mm(inches)

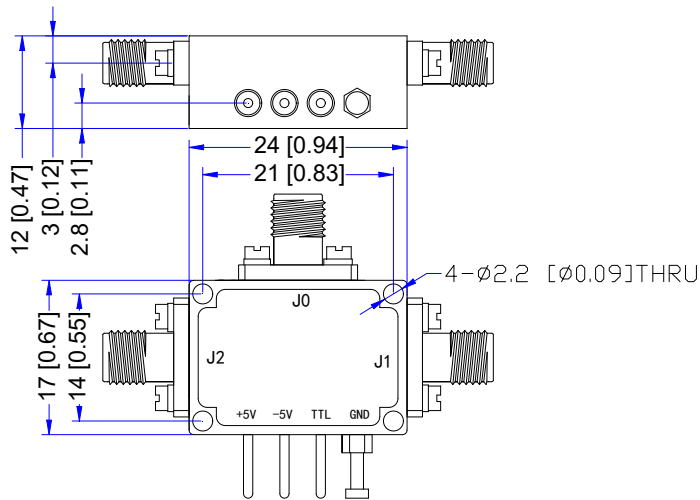

Truth Table	
TTL Control Input	Signal Path State
TTL	
1	J0-J1
0	J0-J2

温度环境 Environmental Conditions:

参数Parameter	Min.	Typ.	Max.	Units
操作温度 Operating Temperature	-45		+85	°C
存储温度 Non-operating Temperature	-55		+125	°C
相对湿度 Relative humidity		95		%
海拔 Altitude	10000		30000	feet
震动 Shock / Vibration(MIL-STD-810F)		Airborne		

订货信息 Ordering Information:

标准型号 Part Number	描述 Description	版本号Revision
TLSPDT0.5G40GA	Absorption, Broadband PIN Switch 0.5-40GHz, SPDT, SMA	Rev.1.1

典型曲线 Typical Performance Data:

VSWR VS Frequency

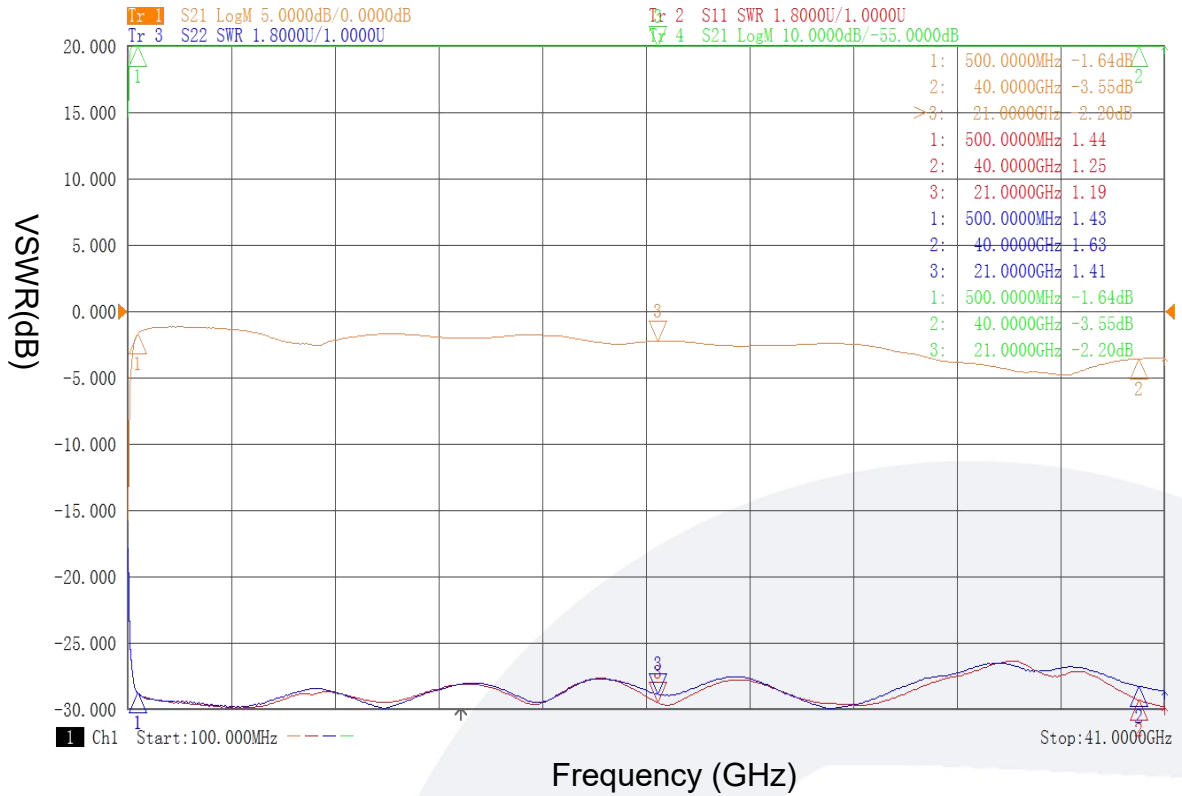

典型曲线 Typical Performance Data:

Isolation VS Frequency

