

Model: TLVP8G12G-200-12

Voltage Controlled Phase Shifter 8-12GHz

Feature:

- Ultra Wide Band: 8-12GHz
- High Phase Shift Accuracy
- High Phase Shift Range
- Single Positive Control Voltage

电气特性 Electrical:

参数Parameter	Min.	Typ.	Max.	单位Units
频率范围 Frequency range	8-12			GHz
插损 Insertion Loss	8-10GHz:	5		dB
	10-12GHz:	4		dB
输入驻波 Input VSWR		1.8		:1
输出驻波 Output VSWR		1.8		:1
移相范围 Phase Shift Range	8-10GHz:	240	500	°
	10-12GHz:	150	250	°
直流电流 DC Supply Current		5		mA
控制电压 Control Voltage Range	0		10	V

机械特性 Mechanical :

参数Parameter	指标 Value	单位Units
输入输出接口 Input /Output Connector	SMA Female	
尺寸 Size	17*17*9	mm
重量 Weight	10	g

绝对最大值 Absolute Maximum Ratings:

参数Parameter	指标 Value
供电偏置电压 Supply Bias Voltage	+11V
输入功率 RF Input Power	+30 dBm
ESD灵敏度 ESD sensitivity (HBm)	Class 0, passed 150V

外形尺寸 Outline Drawing:

Unit: mm(Inches)

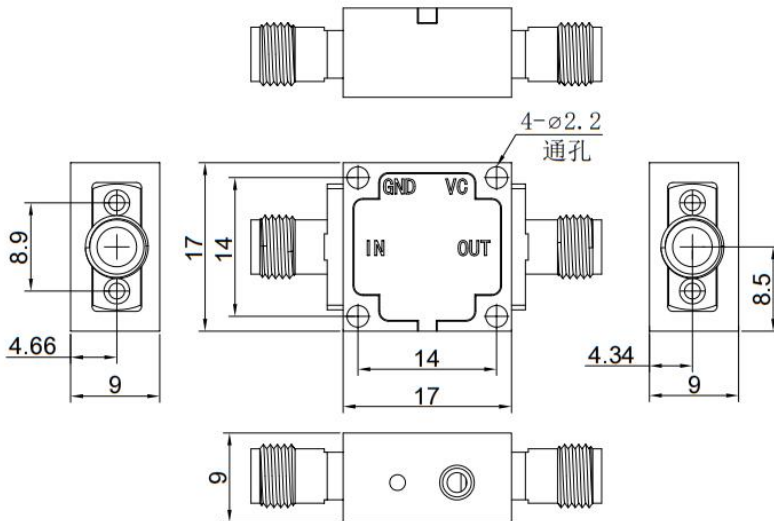

温度环境 Environmental Conditions:

参数Parameter	Min.	Typ.	Max.	单位Units
操作温度 Operating Temperature	-55		+85	°C
存储温度 Non-operating Temperature	-55		+155	°C
相对湿度 Relative humidity		95		%
海拔 Altitude	50,000			feet
震动 Shock / Vibration(MIL-STD-810F)	25g rms (15 degree 2KHz) endurance, 1 hour per axis			
冲击 Shock(non operating)	20G for 11msc half sin wave,3 axis both directions			

订货信息 Ordering Information:

标准型号 Part Number	描述 Description	版本号Revision
TLVP8G12G-200-12	Voltage Controlled Phase Shifter ,8-12GHz,SMA	Rev.1.1

典型曲线 Typical Performance Data:

Phase Shift vs Control Voltage

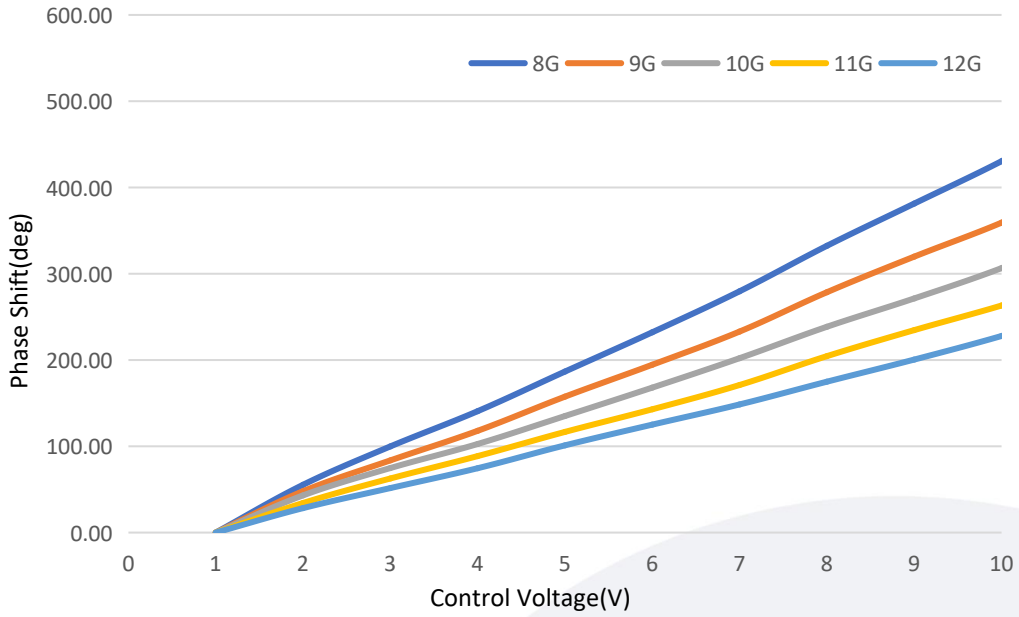

Insertion Loss vs Frequency

